

Chapter 3

A Brief History of Protective Relays

1. Electro-Mechanical Relays

Electro-mechanical relays are considered the simplest form of protective relay. Although these relays have very limited operating parameters, functions, and output schemes, they are the foundation for all relays to follow and can have very complicated mechanical operating systems. The creators of these relays were true geniuses as they were able to apply their knowledge of electrical systems and protection to create protective relays using magnetism, polarizing elements, and other mechanical devices that mimicked the characteristics they desired.

The simplest electro-mechanical relay is constructed with an input coil and a clapper contact. When the input signal (current or voltage) creates a magnetic field greater than the mechanical force holding the clapper open, the clapper closes to activate the appropriate control function. The relay's pick up is adjusted by changing the coil taps and/or varying the core material via an adjusting screw. The relay has no intentional time delay but has an inherent delay due to mechanical operating times.

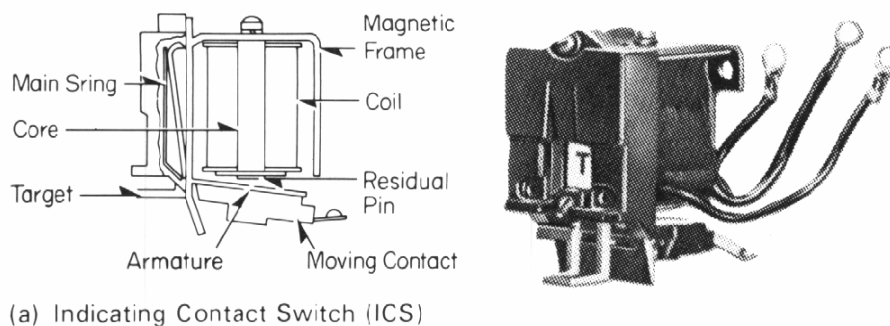

Figure 2- 1: Example of Clapper Style Relay

The next level of Electro-mechanical relay incorporates an internal time delay using a rotating disk suspended between two poles of a magnet. When the input coil's magnetic strength is

Digital Relay Testing – A Practical Guide from the Field

greater than the mechanical force holding the disk in the reset position, the disk will begin to turn toward the trip position. As the input signal (voltage or current) increases, the magnetic force increases, and the disk turns faster. The relay's pick up is adjusted by changing input coil taps and/or adjusting the holding spring tension. The time delay is altered by moving the starting position and varying the magnet strength around the disk. Time characteristics are preset by model.

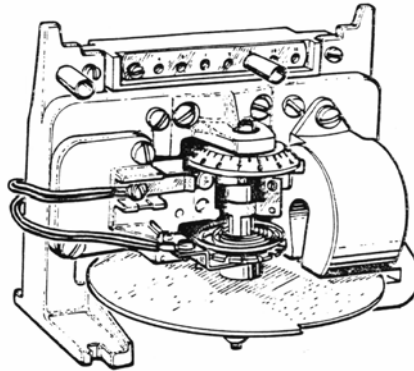

Figure 2- 2: Typical Electro-Mechanical Relay with Timing Disk

The next level of complexity included polarizing elements to determine the direction of current flow. This element is necessary for protective functions such as the following to operate correctly:

- Distance (21)
- Reverse Power (32)
- Loss of Field (40)
- Directional Overcurrent (67)

These relays used the components described previous but their operation is blocked until the polarizing element detects that current is flowing in the correct direction. Polarizing elements used resistors, capacitors, and comparator circuits to monitor current flow and operate a clapper style contact to shunt or block the protective functions accordingly.

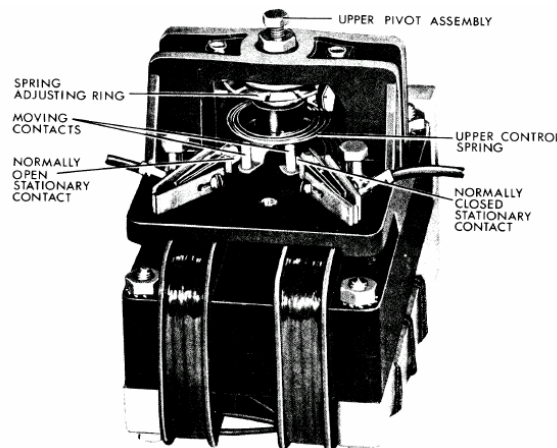

Figure 2- 3: Example of an Electro-Mechanical Relay Polarizing Element